

Digital Valve Amplifier

Series PROam 21

Features

- Power amplifier for proportional directional valves
- Internal controlled by a modern microcontroller
- Compact housing
- Adjustment via potentiometer
- Imin, Imax, RAMP and PWM-frequency adjustment via potentiometer
- Current range (per DIL switch): 0,8A and 1,6A



Technical data

Power supply	[VDC]	10...30 (incl. ripple)
Current consumption	[mA]	<60 + solenoid current
External fuse	[A]	3 (fast)
Analoque inputs	[V]	+/- 10
	[V]	+/- 8
	[V]	0...5...10
	[V]	0...4...8
	[mA]	4...12.20
	[V]	+/- 5
	[V]	+/- 4
	[mA]	4...20
Reference voltages	[V]	8; 10 mA max.
PWM outputs		
max. load	[A]	0,8 or 1,6 (per DIL switchable)
Frequency	[Hz]	70...125
Sample time (signal conditioning)		Depending of the PWM frequency
Adjustments		
Imin	[%]	0...60 (0=preadjusted)
Imax	[A]	0,7...1,6
	[A]	0,4...0,8
RAMP	[s]	0,05...15 (0,05=preadjusted)
PWM Frequency	[Hz]	70...125 (125=preadjusted)
Housing		Snap-On Module EN 50022 Polyamide PA6.6 Combustibility class V0...V2 (UL94)
Protection class	[IP]	20
Temperature range	[°C]	-20...55
Humidity	[%]	<90 (not condensing)
Dimensions	[mm]	120(d) x 100(h) x 23(w)
Connections		RS232: 3,5mm JISC-6560 4x4pol. Screw terminals PE: direct via DIN rail
EMC		EN 50081-1 EN 50082-2

Block diagram

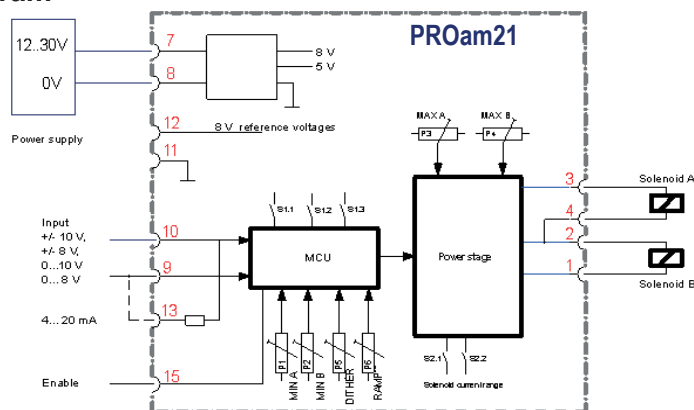

AMCA Hydraulic Fluid Power BV

P.O. Box 18 | 9790 AA Ten Boer
B. Kuiperweg 33 | 9792 PJ Ten Post
The Netherlands

Tel.: +31 (0)50-3023577 | Fax: +31(0)50-3021226
sales@amca-nl.com | www.amca-nl.com